



PO Box 128

| 504 Highway 63 South

| Freeburg, MO 65035

| 800-347-0438

| 573-469-4151 (fax)

Installation Guidelines for all Quaker products with Standard Sub-sill and Receptor System

Read these instructions completely before starting any installation. Failure to install and maintain our product according to these instructions may void any product warranty. Please visit our website at www.quakerwindows.com or call 1-800-347-0438 for additional information.







Tools required by installer:

Safety glasses		Utility knife	
Drill/Driver		Caulk gun	
Level		Tape measure	
Rubber mallet		Pop-rivet gun	
Metal cutting saw			

Materials required by installer:

Foam Backer Rod		Minimally Expanding Foam	
Shims (Waterproof)		Sealant	
Fasteners		Denatured Rubbing Alcohol	

Quaker Supplied Parts:

Sub-sill		End Dam	
Pop rivets		U-channel	
Wedge gasket		Receptor & clip	

WARNING

Tools

- Follow manufacturers instructions for safe operation of tools, and ladders/scaffolding. Always wear safety glasses. Failure to do so could result in injury, product or property damage.

Handling

- Do not store units outside, or in a hot environment. Doing so could result in product damage.
- Do not carry flat.** Doing so could result in product damage, injury, or property damage.
- Stack units as straight as possible to avoid bowing. **Do not lay flat!**

Glass

- If broken, glass can fragment causing injury. All Quaker products are available with safety glass. In many areas, local building codes require safety glass in certain locations and/or applications. Unless safety glass is ordered, Quaker windows are not provided with safety glass. Before ordering, consult your local building codes for more definitive information.

Fastening

- Metal fasteners and components could corrode when used with preservative-treated lumber. Use approved fasteners and components to fasten window or door. Failure to do so could cause a failure resulting in injury, product or property damage.
- Fastener must attach to a structural framing member with 1 1/2" minimum fastener embedment, or minimum 3 full threads with a minimum 5/16" head as products were tested with.
- Quaker does not supply anchorage/fastener calculations, and is not responsible for determining structural adequacy of the anchorage and fasteners used to install our products, or the openings into which they are installed.**
- Do not** over drive screws or nails. Doing so could result in product damage.

CAUTION**Installation**

- Always support window or door in opening until fully fastened. Failure to do so could result in the window or door falling out or causing injury, product, or property damage.
- Nailing flanges and drip caps (integral or applied) **do not** take the place of window flashing. All windows and doors must be properly flashed and sealed with material compatible sealant for protection against water and air infiltration around the entire perimeter. Failure to do so could result in product or property damage.
- **Do not** set window directly on sill plate. Place shims under the side jambs. Window or door must be properly shimmed. Failure to do so could affect operation and product performance and could result in product damage.
- Live or dead loads transferred into our product can affect functionality, damage frame joinery or cause glass failures. Dead loads such as upper levels, roof, etc. Should be constructed before window or door is installed.
- Loads shall be designed to withstand the most critical effects of load factors and load combinations as required by the building code. (Loads are including but not limited to Live, Dead, Collateral, Auxiliary, Thermally induced, Seismic, etc.)
- Maximum vertical deflection of the header under all Load combination should not exceed the Span/720 or 1/4" whichever is less.
- Windows and doors have small parts. Small parts if swallowed could pose a choking hazard to young children. Dispose of unused, loose, or easily removed small parts. Failure to do so could result in injury.
- **Do not** drill through or into window sill to install alarm wires.

Sealing

- Follow instructions of foam, sealant, and flashing manufacturers regarding safety, material application, compatibility, and periodic maintenance for continued weather resistance of their products. Failure to do so could result in product or property damage. **DO NOT** overfill between the frame and opening.
- Minimally expanding foam insulation must be compliant with AAMA 812-04.
- Quaker recommends 100% silicone (ASTM C920 compliant) neutral cure only sealant. Always clean all areas where sealant will be applied. Failure to do so could result in product or property damage.
- Flashing tape must meet ASTM-D779 performance requirements.
- Maintain a minimum of 1/4" between the window or door frame and exterior finish materials. Failure to do so could result in product or property damage.

Joining

- Do not join any window or door to any window or door not designed for joining. Joined windows and doors must be individually supported in the opening. Failure to do so could affect operation and product performance and could result in product or property damage.

Cleaning

- Acid solutions used for cleaning will damage glass, fasteners, hardware, and metal flashing. Protect these products and follow cleaning products manufacturers instructions. If acid contacts the window or door, wash all surfaces immediately with clean water.
- **Do not** use razor blades to clean glass surface. Glass damage could result.
- Clean glass using liquid glass cleaner.
- Clean frame, sash, panels, and insect screens using mild detergent and warm water with a soft cloth or brush.

IMPORTANT

- Buildings constructed prior to 1978 could contain lead paint which could be disturbed during window or door replacement. For more information on proper management of lead paint, go to: www.epa.gov/lead
- Care must be taken to properly recycle or dispose of old materials. Any recyclable materials should be separated from non-recyclable or hazardous materials. Please consult with local or state authorities regarding proper disposal of non-recyclable or hazardous materials.
- These are generic instructions intended to cover most common situations, which may not be appropriate for all installations due to building design, construction materials, or methods used and/or building or site conditions. Consult a contractor or architect for recommendations.
- Inspect all units for any damage or defects prior to installation. Contact the nearest Quaker distributor if there are any problems.

1

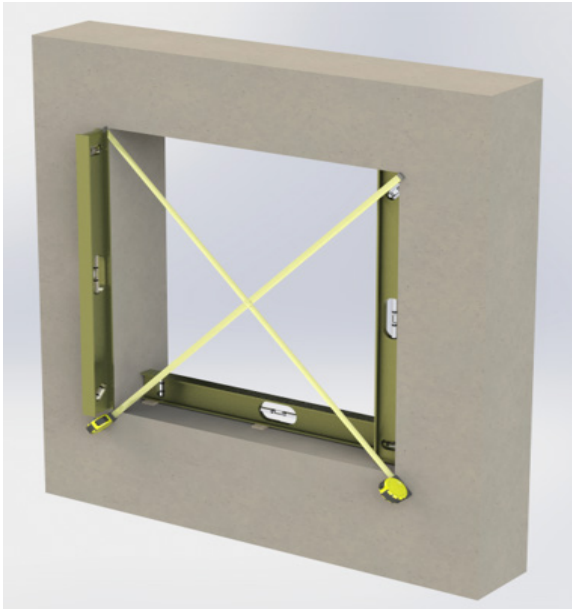

Measure and verify the size of the rough opening. See shop drawings for the proper opening sizes per sub-sill and receptor system being used. Verify the rough opening is flat, plumb, level, and square. Take diagonal measurements to check for square. The sill beneath the unit must be level for proper unit operation.

2



Check the fit of the sub-sill making sure the conditions are level, the installer can pre-apply the shims to the sill condition prior to installation of the sub-sill.

3

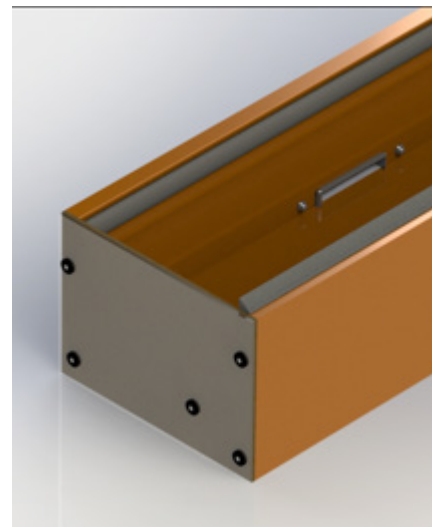
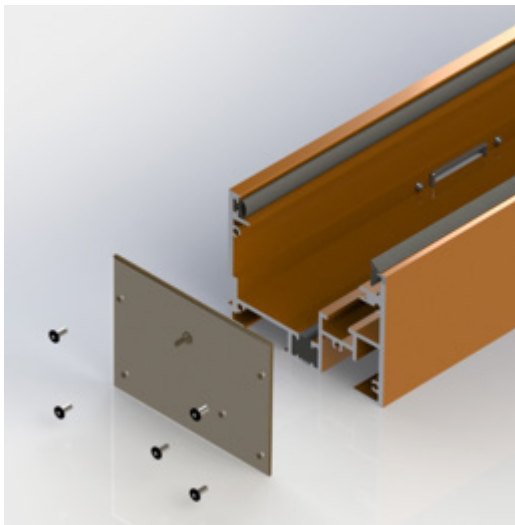

Measure the opening and trim the sub-sill (per shop drawings) typical $\frac{1}{8}$ " to $\frac{3}{8}$ " less than opening to allow for end dams and rivet heads. Note: You may want to cut the sub-sill on both sides to center weep holes in opening. If using U-channel installation method for sub-sill cut the U-channel to match sub-sill length. When applying end dams, make sure to properly clean off the ends of both the sub-sill and the end dam with appropriate solvent to ensure a good seal. After applying solvent, immediately dry off the material. Do not allow the solvent to air dry on the material. Note: It is critical that this step not be overlooked as oil, grease and dirt deposited during the manufacturing process can have a detrimental effect on the adhesion capability of the sealant. Fasten the end dam with supplied pop-rivets.

4

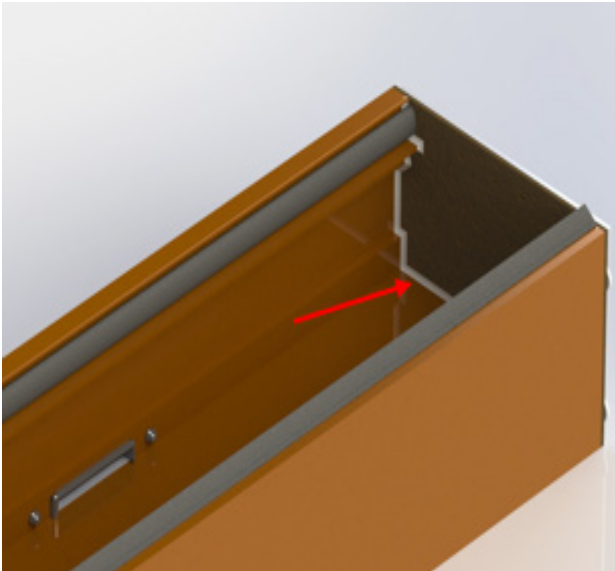

Apply self-leveling sealant to the inside edge between the sub-sill and the end dam covering all edges.

5

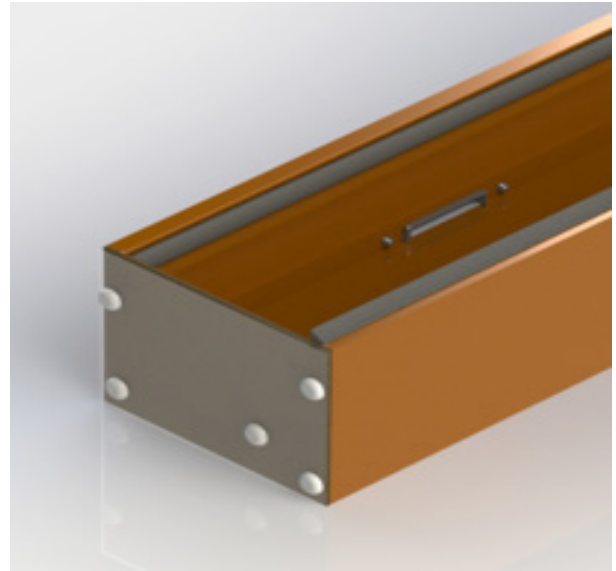

Apply a cap bead of sealant over all pop-rivet heads. Repeat steps 3-5 for the other side of sub-sill.

6

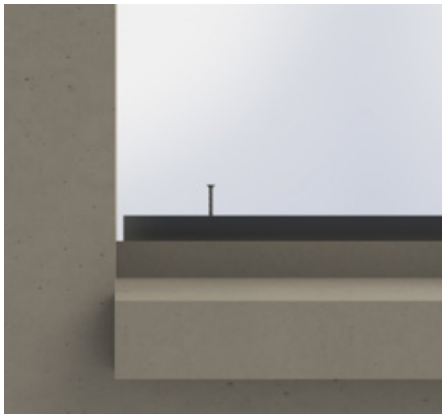

If flashing is present, determine where the window will be positioned to ensure that the perimeter seal is inboard of the flashing so water drainage will occur outboard of the perimeter joint at the head receptor.

Once the location is determined test fit the sub-sill and check for level. Shim as need to achieve a level sill, and mark the outside edge of sub-sill. This mark will be used to measure the placement of the U-channel. Remove sub-sill. Install the U-channel $2 \frac{7}{16}$ " to the interior of the mark (or exterior of sub-sill).

Make sure to center the U-channel in opening to allow for the end dams to slide over the ends.

7

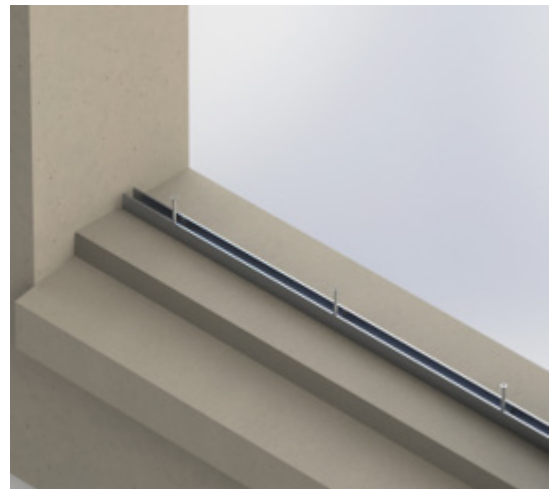

Pre-drill holes and fasten the U-channel with screws by others per shop drawings or anchorage calculations. Typically 3" from the ends and 12" on center.

8

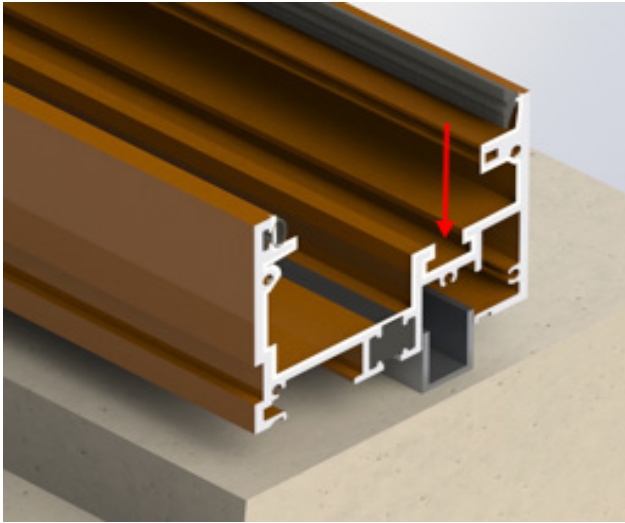

Set the sub-sill over the U-channel as shown above.

9

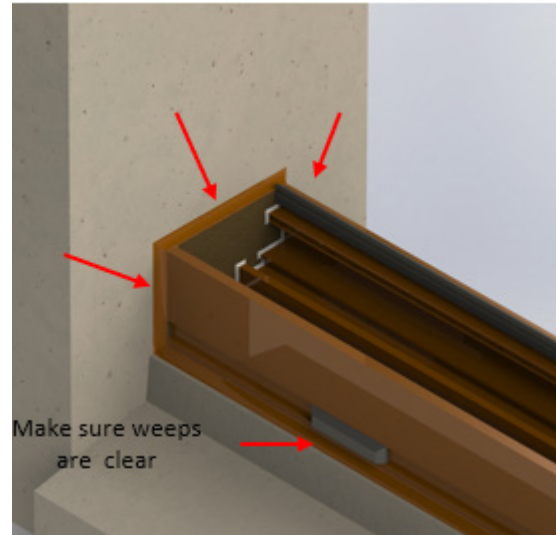

Apply sealant at the end of the end dams to the opening and along the bottom edge of sub-sill to opening. Make sure not to block weeps with sealant.

10

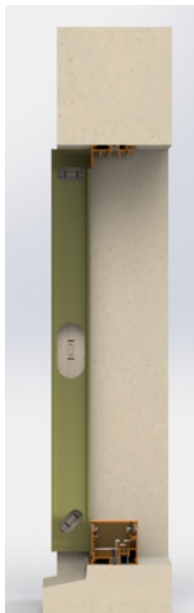

Square cut the head receptor and clip $\frac{1}{2}$ " less than horizontal opening to allow for proper joint geometry. Trim weather strip to appropriate length using caution not to stretch material. Use a story board or straight edge to level up from the sub-sill to locate the head receptor location.

11

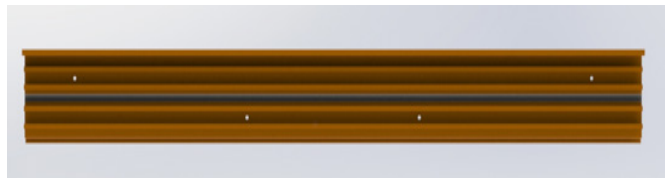

Drill pilot holes into the receptor at shimmed locations to install head receptor. Fasten receptor with screws by others per shop drawings or anchorage calculations. Typically 3" from the ends and 12" on center.

12

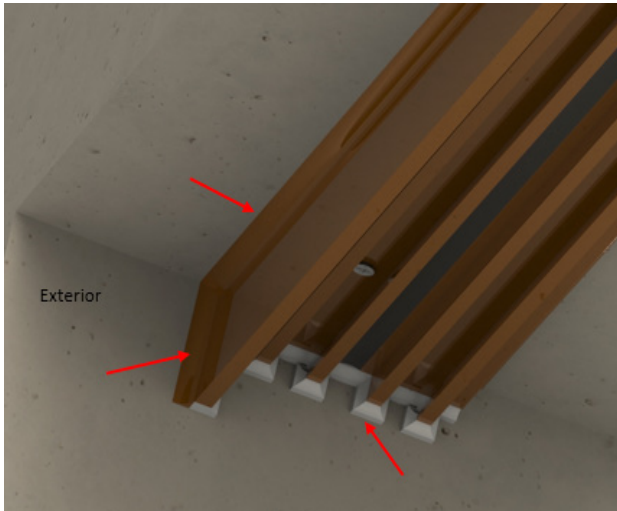

Shim as needed to level head receptor before tightening all screws.
Apply sealant between receptor exterior and opening. Also seal both ends of head receptor to the opening

13



Measure from top of sub-sill to the bottom leg of head receptor and square cut the jamb receptor. Trim weather strip to appropriate length using caution not to stretch material.

14

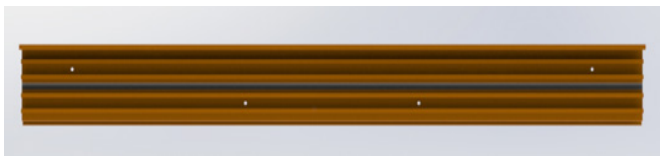

Drill pilot holes into the receptor at shimmed locations to install jamb receptor. Fasten receptor with screws by others per shop drawings or anchorage calculations. Typically 3" from the ends and 12" on center.

15

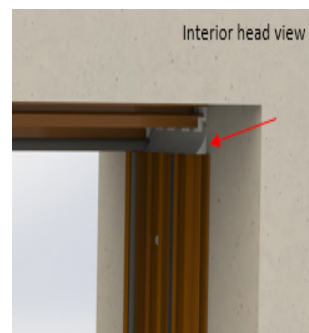
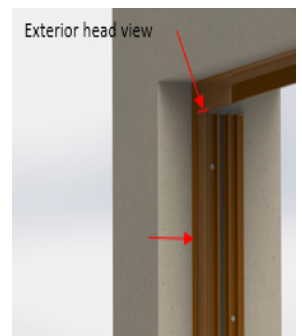
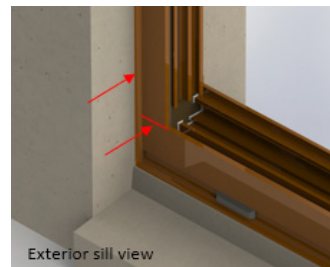

Shim as needed to level jamb receptor before tightening all screws. Apply sealant between receptor exterior and opening. Also seal both ends of head receptor to the opening.

16

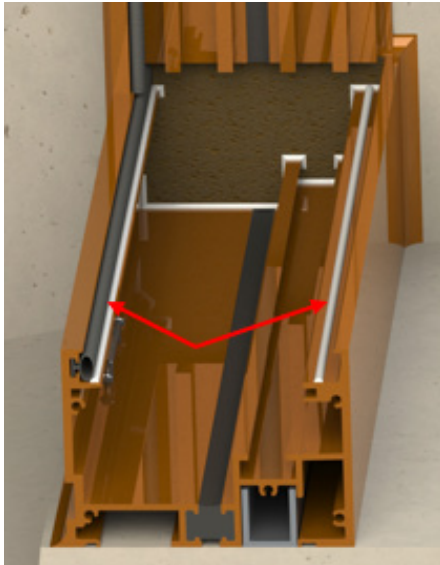

Apply a bead of sealant to the legs of the sub-sill where the window will rest. Center window in opening and set the exterior leg of the window onto the sub-sill frame, then push the window head and jamb in against the head and jamb receptors. Snap in temporary closer pieces to hold window into place.

17

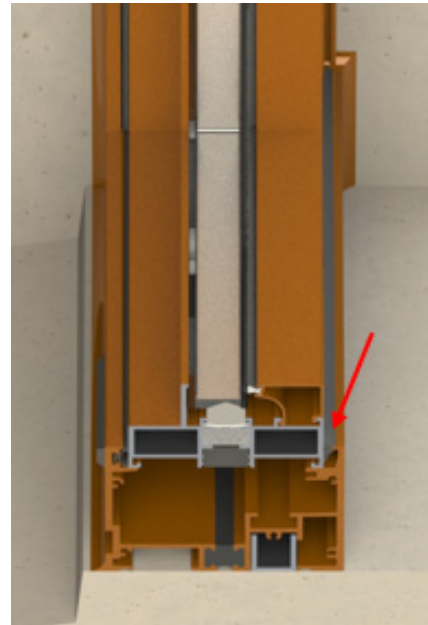

Place a level on the window sill to verify that the sill is level. Adjust the shims as needed to ensure a level condition. Apply the sub-sill wedge gasket into the interior side of the sub-sill against the window as shown above.

18

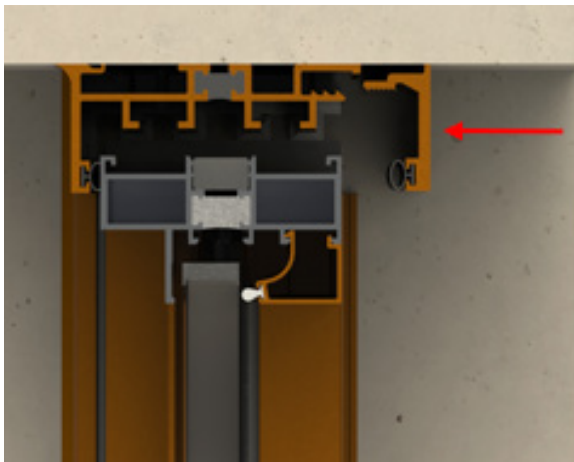

Measure opening and cut the head receptor closer clip. Trim weather strip to appropriate length using caution not to stretch material. Install clip using a rubber mallet to make sure the closer clip snaps into place.

19

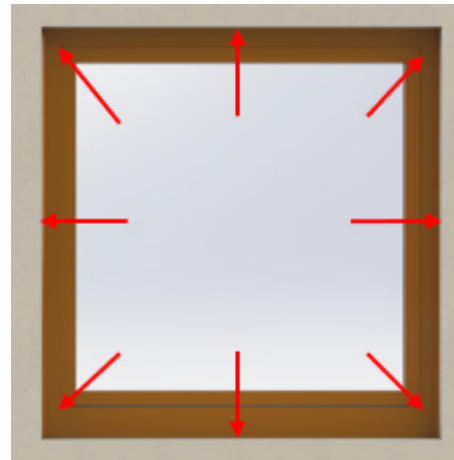

Measure between the sub-sill and head receptor clip and cut the jamb receptor closer clips. Trim weather strip to appropriate length using caution not to stretch material. Install clip using a rubber mallet to make sure the closer clip snaps into place. Check the installed product to ensure that it operates properly and that the reveal is equal between the sash and frame. Apply sealant around the interior perimeter between closer clips and opening and all joints.



Installation Guidelines For All Quaker Products With Standard Sub-Sill and Receptor System

If this set of instructions doesn't match your installation method or wall conditions please check our website listed below for other options, or call the office.

Scan here for a digital version of these guidelines in English



Scan here for a digital version of these guidelines in Spanish



Or go to: <http://quakerwindows.com/installation-instructions-videos/>

Or go to: <http://quakerwindows.com/installation-instructions-spanish/>

