

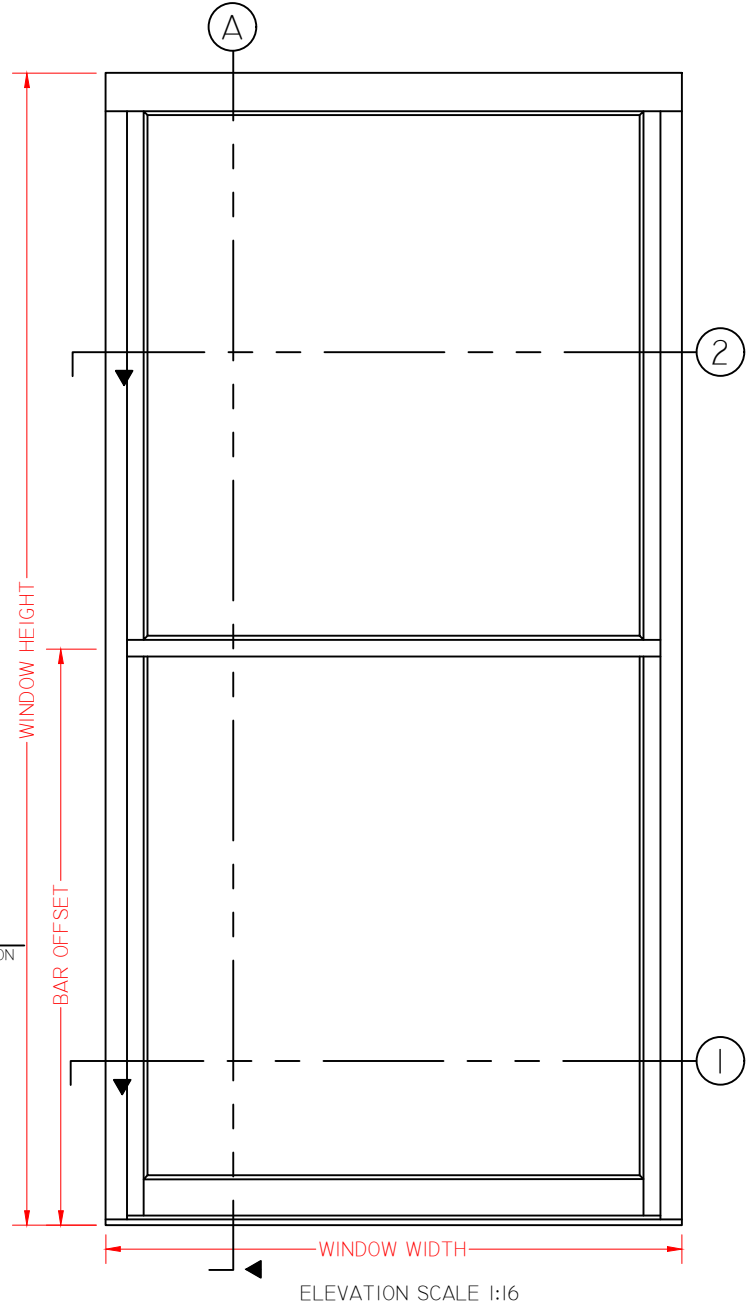

# EDGE LINE (H655) SINGLE HUNG NAIL FIN W/ SCREEN (12LB)

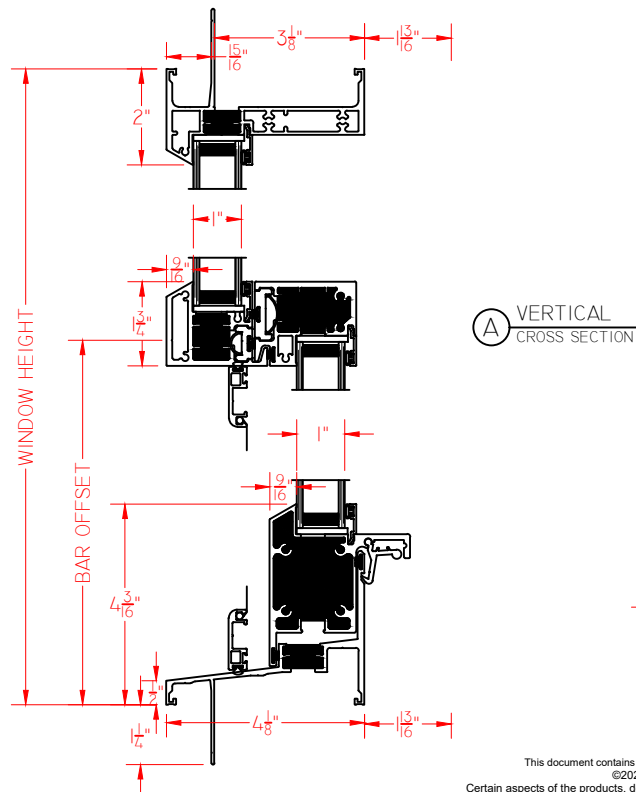
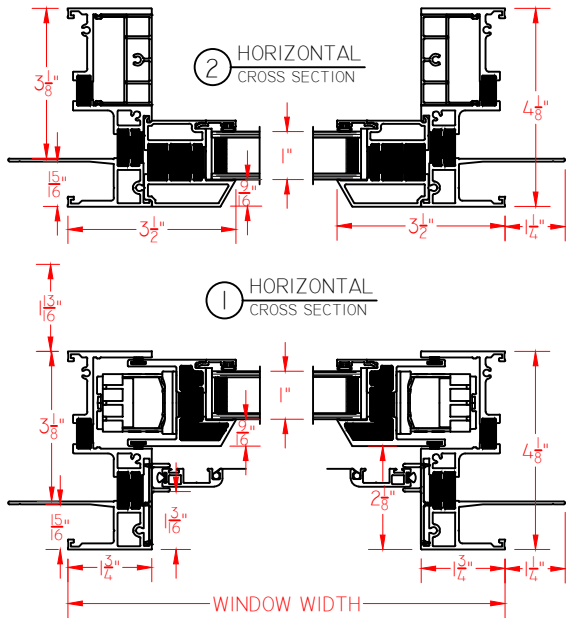

This document contains CONFIDENTIAL and proprietary information intended for the private use of Quaker.  
©2021 Quaker Window Products Co. ALL RIGHTS RESERVED.  
Certain aspects of the products, designs, or methods shown may be subject to patent rights or pending patent applications.  
For more information, see <https://quakerwindows.com/patents/>