

TimberLine Awning (W600/W605)

Technical Data Sheet

Frame/Sash

- Architectural Grade 6063-T63 Aluminum
- Euro-Groove Mainframe/Sash
- Azo-Core Thermal Break (Mainframe/Sash)
- 45 Degree Mitered Mainframe/Sash Corners
- Silicone Injected Corner Keys
- 4-1/8" Overall Frame Depth
- 2-7/8" Exterior Sightlines
- 1-1/4" Pre-Punched Nail Fin
- Overlapping Sash to Mainframe
- Radiatta Pine Interior

Weather stripping

- Dual Bulb Seal Gaskets

Glazing

- Beveled/Square Exterior Glazing Stops
- Quanex Super Spacer
- 100% Silicone Wet Glaze
- Double/Triple Insulated Glass Options
- Annealed, Tempered, Laminated and Obscure Glass Options Available

Hardware

- Stainless Steel Four-Bar Hinge
- Dual Low Profile Lock Lever Operating Multiple Lock Points
- Stainless Steel Hardware Available
- WOCD Available

Mulling Options

- Continuous Frame Configurations
- Field Applied Structural Mulls

Grid Options

- Grids Between the Glass
- Simulated Divided Lites

Screen

- Flex Screen Standard

Paint

- 2604/2605 FGIA High Performance Powder Coatings
- 30 Standard Colors
- Custom Colors available

TimberLine Awning (W600/W605)		
NAFS Rating	AW-PG70-C	
Design Pressure (P.S.F.)	70	
Air Infiltration at 25 MPH (cfm/ft ²)	0.09	
Water Resistance	12	
U-Value (Based on Cardinal 366 Low-E/Argon Fill)	0.29	
SHGC (Based on Cardinal 366 Low-E/Argon Fill)	0.19	
Frame Sizing	Width	Height
Minimum	24"	24"
Maximum	72"	84"



Quaker Window Products
504 U.S. Hwy 63 South
Freeburg, MO 65035
(800) 347-0438
www.quartzluxurywindows.com

Discover More Here:



QTZ-TL-AWN-0124

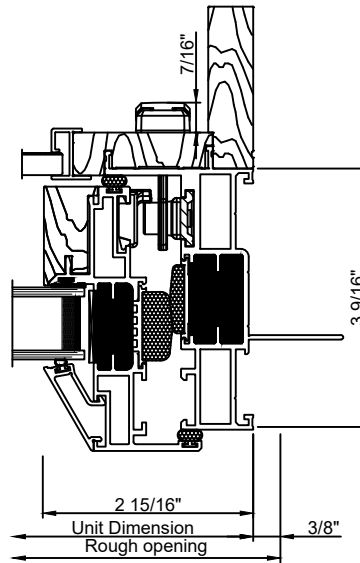
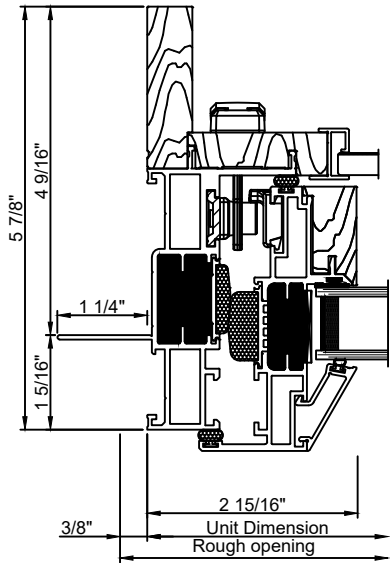

Window cut sections 3/8" = 0' 1"

Exterior

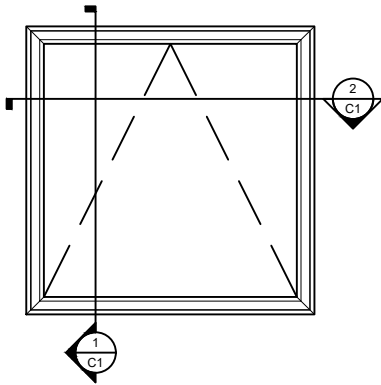

Window Elevation 3/8" = 1' 0"

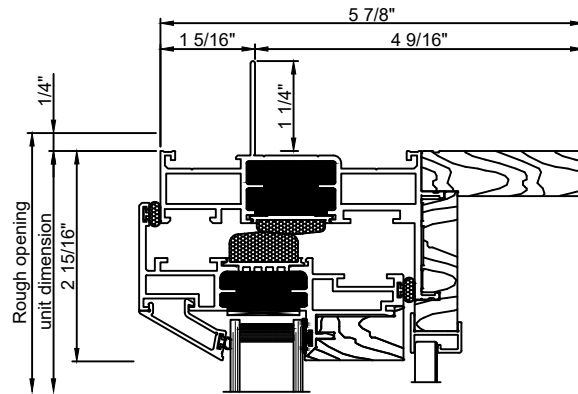

Exterior

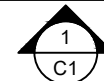
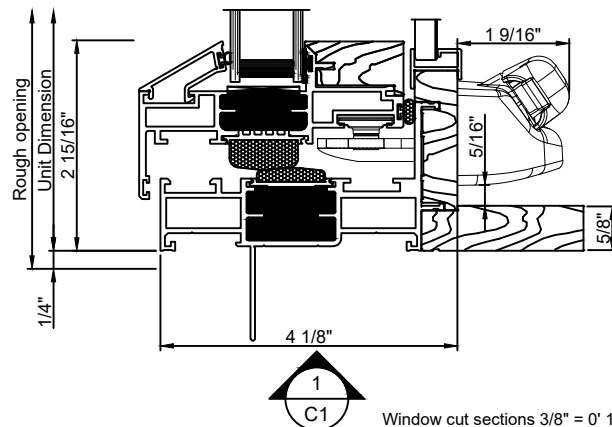

Window cut sections 3/8" = 0' 1"

Note: All dimensions are approximate. Quaker reserves the right to change specifications without notice.

TimberLine (W605) Bevel Push Out Awning Window

Cross section details

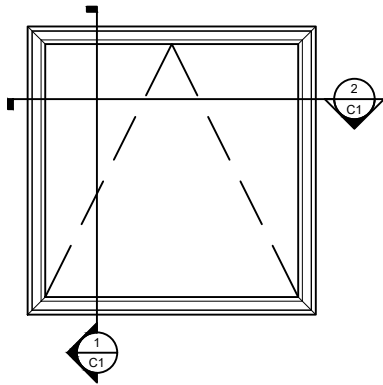
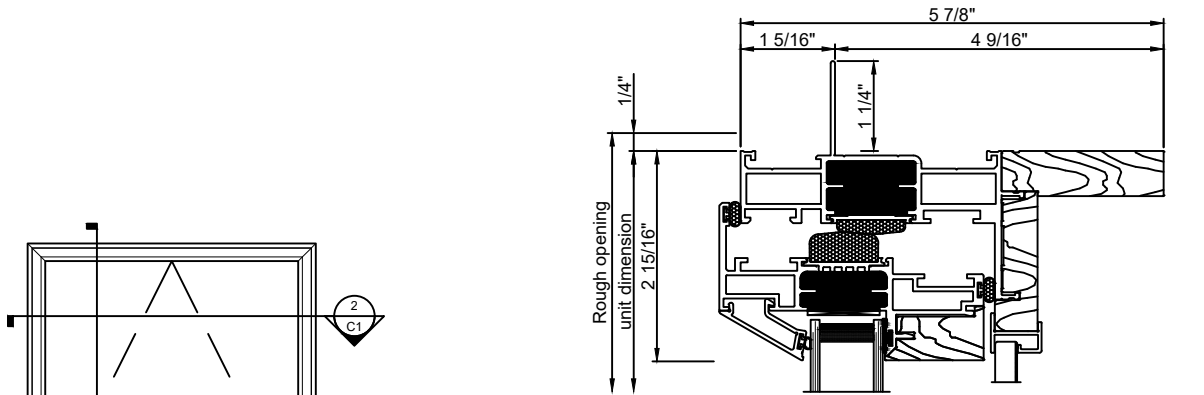
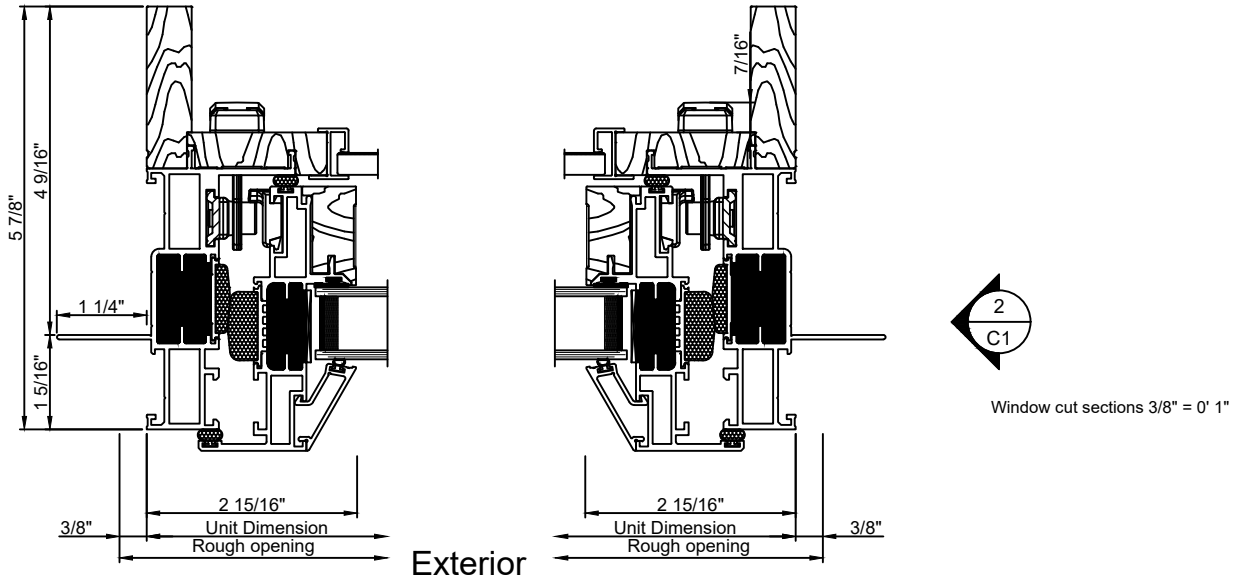

Window Elevation 3/8" = 1' 0"

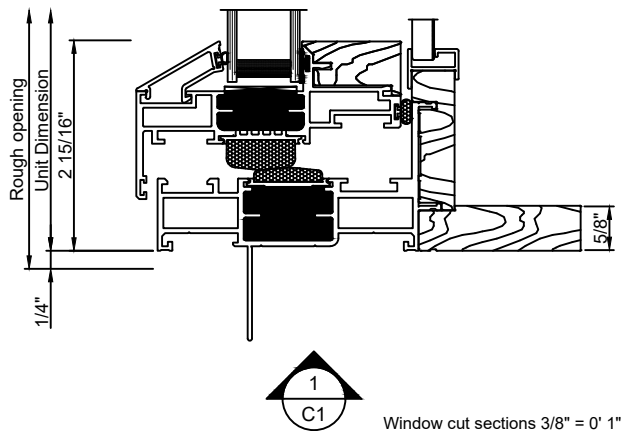

Note: All dimensions are approximate. Quaker reserves the right to change specifications without notice.

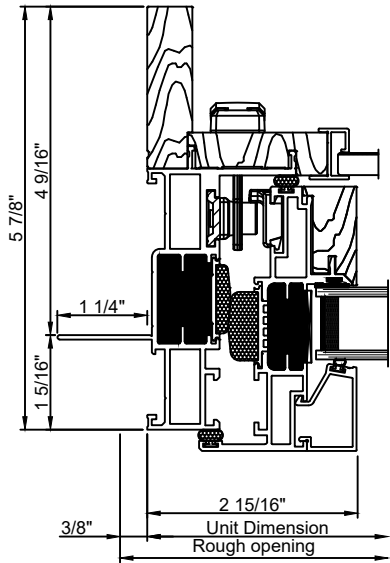

Exterior

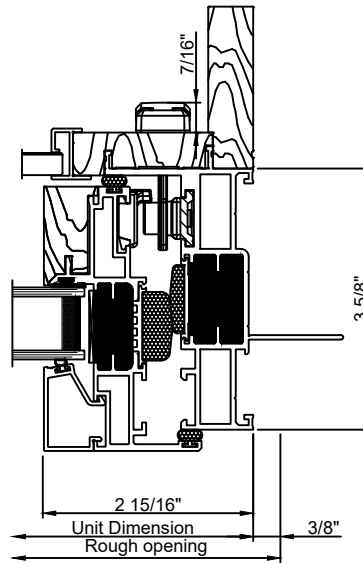

Window cut sections 3/8" = 0' 1"

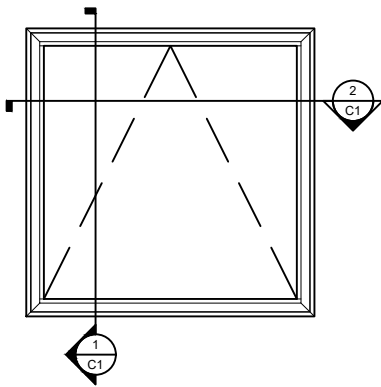

Window Elevation 3/8" = 1' 0"

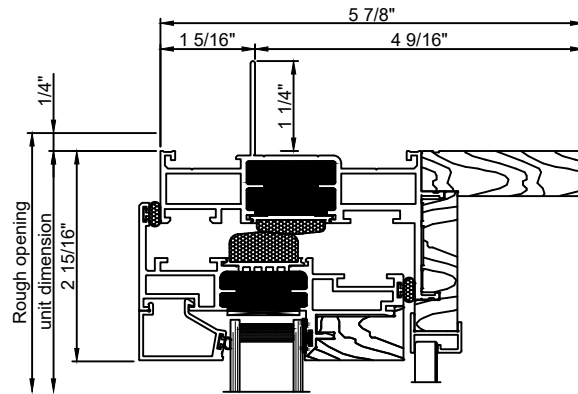

Exterior

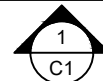
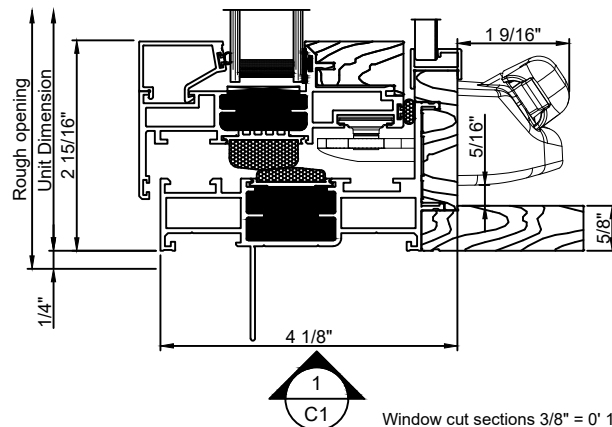

Window cut sections 3/8" = 0' 1"

Note: All dimensions are approximate. Quaker reserves the right to change specifications without notice.

TimberLine (W600) Square Push Out Awning Window

Cross section details

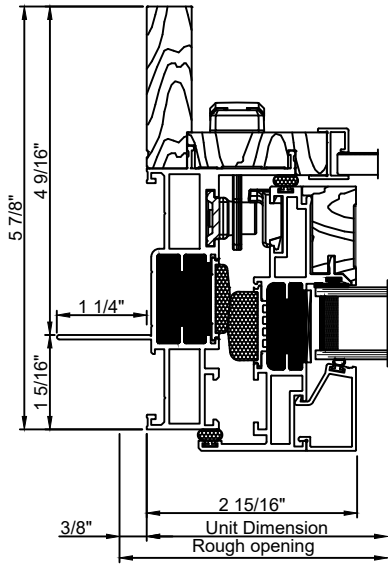

Exterior

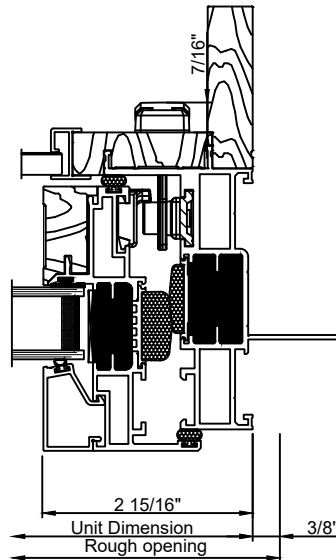

Window cut sections 3/8" = 0' 1"

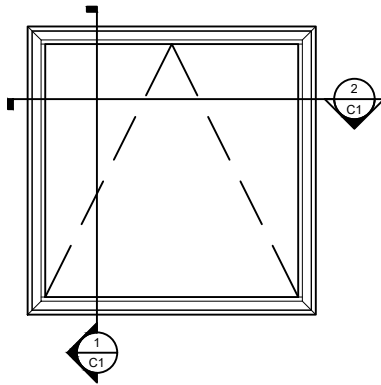

Window Elevation 3/8" = 1' 0"

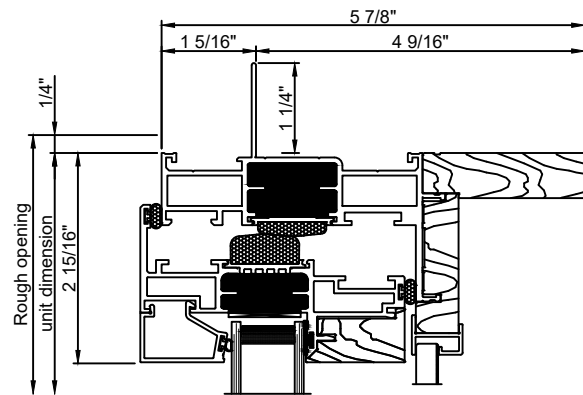

Exterior

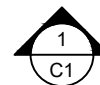
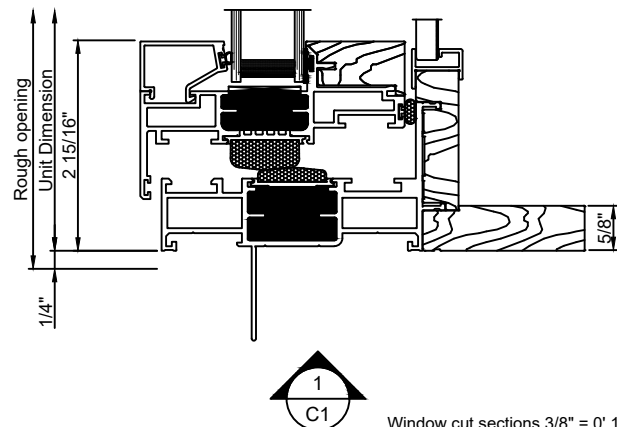

Window cut sections 3/8" = 0' 1"

Note: All dimensions are approximate. Quaker reserves the right to change specifications without notice.